

## GM Mount HP Efficient Alternators

### Features:

**Fits Chevrolet and GMC Chassis**

- Efficient
- High Output

**12V - 240A**

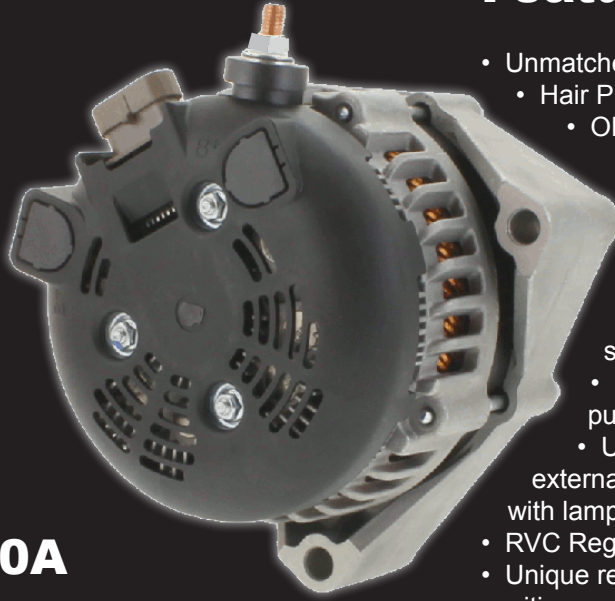

- Unmatched charging curve at idle - exceeding 170 amps
- Hair Pin, 6 phase stator maximizes slot fill
  - OEM engineered to produce high output - this is not a "Pumped Up" auto unit
  - 12 press fit 70A diodes with welded leads
  - Unmatched heat recovery
  - Super high heat bearings with 200+ degree seals and synthetic grease
  - 96 slot stator compared to 36 slot provides superior efficiency
  - Shaft design accepts passive, IDP, and OWC pulley designs
  - Universal Regulator circuit adapts to internal or external sensing as well as PCM or ignition excitation with lamp control
- RVC Regulator for specific applications
- Unique rectifier design allows for 3 different output post positions

### Typical HP Series Output Curve

RPM	1000	2000	3000	4000	5000
AMPS	6	173	217	235	242

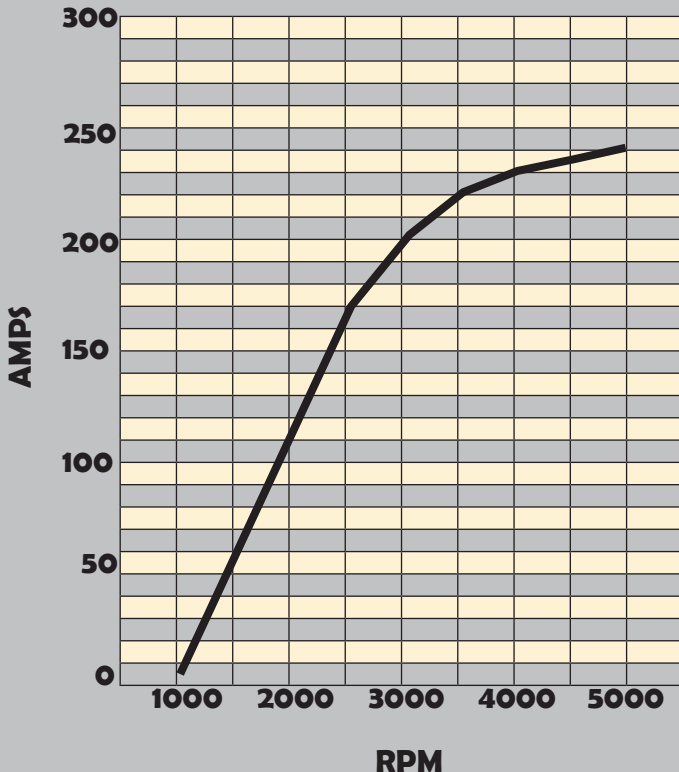

### See the Difference?

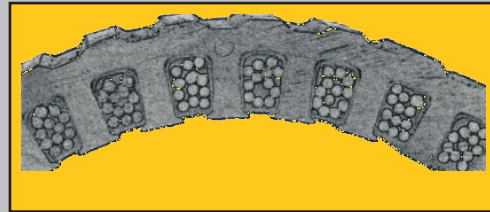

Round Wire Stator with Air Gaps Limiting the Slot Fill

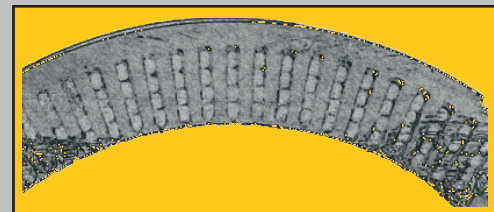

Hair Pin Stator with Solid Copper Maximized the Slot Fill and Copper to Steel Coupling

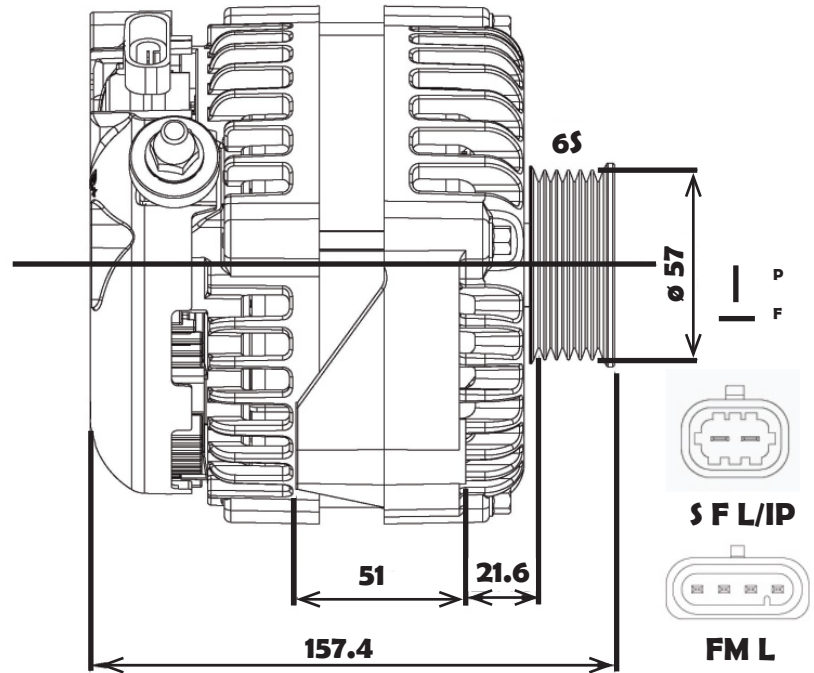
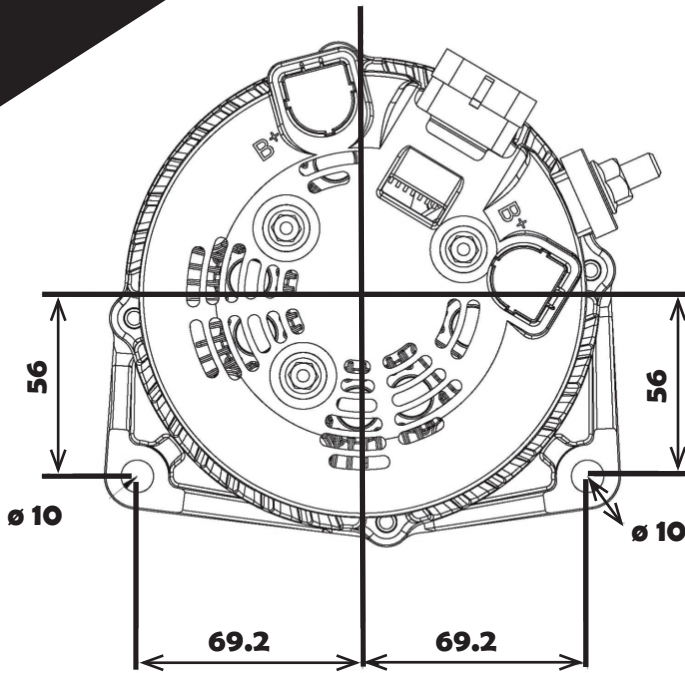

## AVAILABLE OPTIONS

### 8292ND-240A

#### 6G SERPENTINE PULLEY, CSD PLUG

REPLACES: Delco AD244 series, DR44G series, 10464476, 15754097, A, M, W, 15-22-6003, 6019239, 8-1046-476-0, 8-15226-003-0

KARAM #: 8495,8540, 8237, 8247

FITS: 1996 - 2012 BUICK, CADILLAC, CHEVY, GMC, HUMMER, ISUZU, SAAB 3.4L, 4.3L, 4.8L, 5.0L, 5.7L, 6.0L, 6.5L & 6.6L Diesel, 7.4L, 8.1L Engines

### 8302ND-240A

#### 6G SERPENTINE PULLEY, RVC PLUG

REPLACES: Delco DR44G series, 10392759, 15263858, 15857609, 15905872, 25869451, 10392573

KARAM #: 8302

FITS: 2005-2008 GMC, CHEVY, CADILLAC SUV/PICKUP with 4.3L, 4.8L, 5.3L, 6.0L Engines

NOTE: RVC Regulator

### PX4VND-240A

#### 6G SERPENTINE PULLEY, EXTERNAL REGULATOR

REPLACES: PENNTEX PX4V series

KARAM #: 8206

FITS: CHEVROLET, GMC Light Trucks

NOTE: Externally Regulated

### 8489ND-240A

#### 6G CLUTCH STYLE PULLEY, CSD PLUG

REPLACES: Delco DR44G series, 15845337, 15845338,

KARAM #: 8299, 8489

FITS: 2006-2007 CHEVY, GMC Car/Light Truck with 6.6l Diesel Engine

### 8499ND-240A

#### 6G CLUTCH STYLE PULLEY, RVC PLUG

REPLACES: Delco DR44G series, 15288860

KARAM #: 8499

FITS: 2007-2009 CHEVY Trailblazer 6.0L Engine, 2008-2009 SAAB 9-7X 6.0L Engine  
 6G CLUTCH STYLE PULLEY, RVC PLUG

### PX520GND-240A

#### 6G SERPENTINE PULLEY, EXTERNAL REGULATOR

REPLACES: PENNTEX PX-520GD, PX5GD-230

FITS: 2002-2007 HUMMER H2 6.0L Engine

NOTE: Externally Regulated, Optional

2.0" Pulley 24-1273